

# AVERY DENNISON MARKETING SPECIFICATION

© 2021 AVERY DENNISON CORPORATION. ALL RIGHTS RESERVED

## HISTORY

REV.	DATE	DESCRIPTION
A	04.17.22	RELEASED

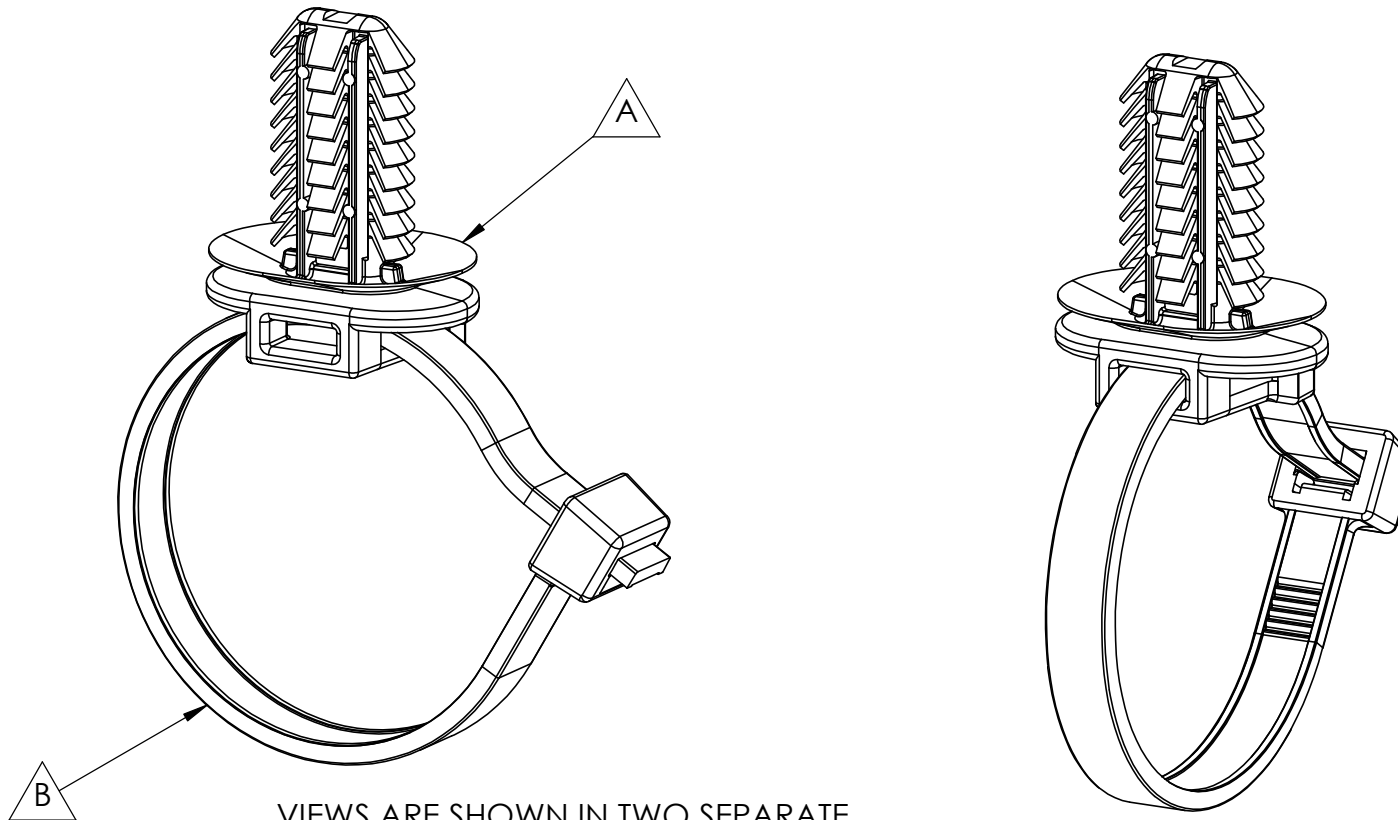

VIEWS ARE SHOWN IN TWO SEPARATE ASSEMBLED CONFIGURATION

NOTES:

1. SEE SPECIFIC OVAL FIR TREE CLIP AND CABLE TIE MARKETING SPECS FOR ADDITIONAL PART PERFORMANCE SPECIFICATIONS
2. OVAL FIR TREE CLIP MEETS ALL USCAR-44 SPECIFICATIONS
3. PARTS ARE NOT SOLD SEPARATELY AND ARE BOXED AS A KIT.
4. PARTS BOXED UNASSEMBLED.

ITEM#	SKU #	DESCRIPTION	MATERIAL	COLOR
A	20316-0	OVAL FIR TREE CLIP, 24mm, IMHS	PA66 IMHS	BLACK
B	12101-0	7.5" CABLE TIE, STD	PA66 IMHS	BLACK

<b>APPROVALS:</b>	ENG. APPR.	<i>D. Gilbertson</i>	04.17.22
	Q.A. APPR.	<i>R. Estano</i>	04.17.22



FASTENER DIVISION  
 FITCHBURG, MA 01420 U.S.A.  
 TEL. 1-800-225-5913  
 FAX. 978-353-8157

<u>SPECIFIED TOLERANCES ARE:</u>		MATERIAL	DESCRIPTION	STOCK NO.	REV.
.XX ± .03 INCHES	.X ± .7 mm	SEE TABLE	OVAL FIR TREE CLIP, 2 PIECE, 24mm, STD, IMHS		
.XXX ± .010 INCHES	.XX ± .25 mm	COLOR	SEE TABLE	<b>20318-0</b>	<b>A</b>
ANGULAR: ± 2°					

CLIP & CT ASSY WEIGHT:	3.7g
PACKAGING:	PACKED SEPARATELY IN ONE BOX 1000 CLIPS/BAG, 5/BOX 1000 CT/BAG, 5/BOX

# AVERY DENNISON MARKETING SPECIFICATION

© 2021 AVERY DENNISON CORPORATION. ALL RIGHTS RESERVED

## HISTORY

REV	DATE	DESCRIPTION
A	04.17.22	RELEASED

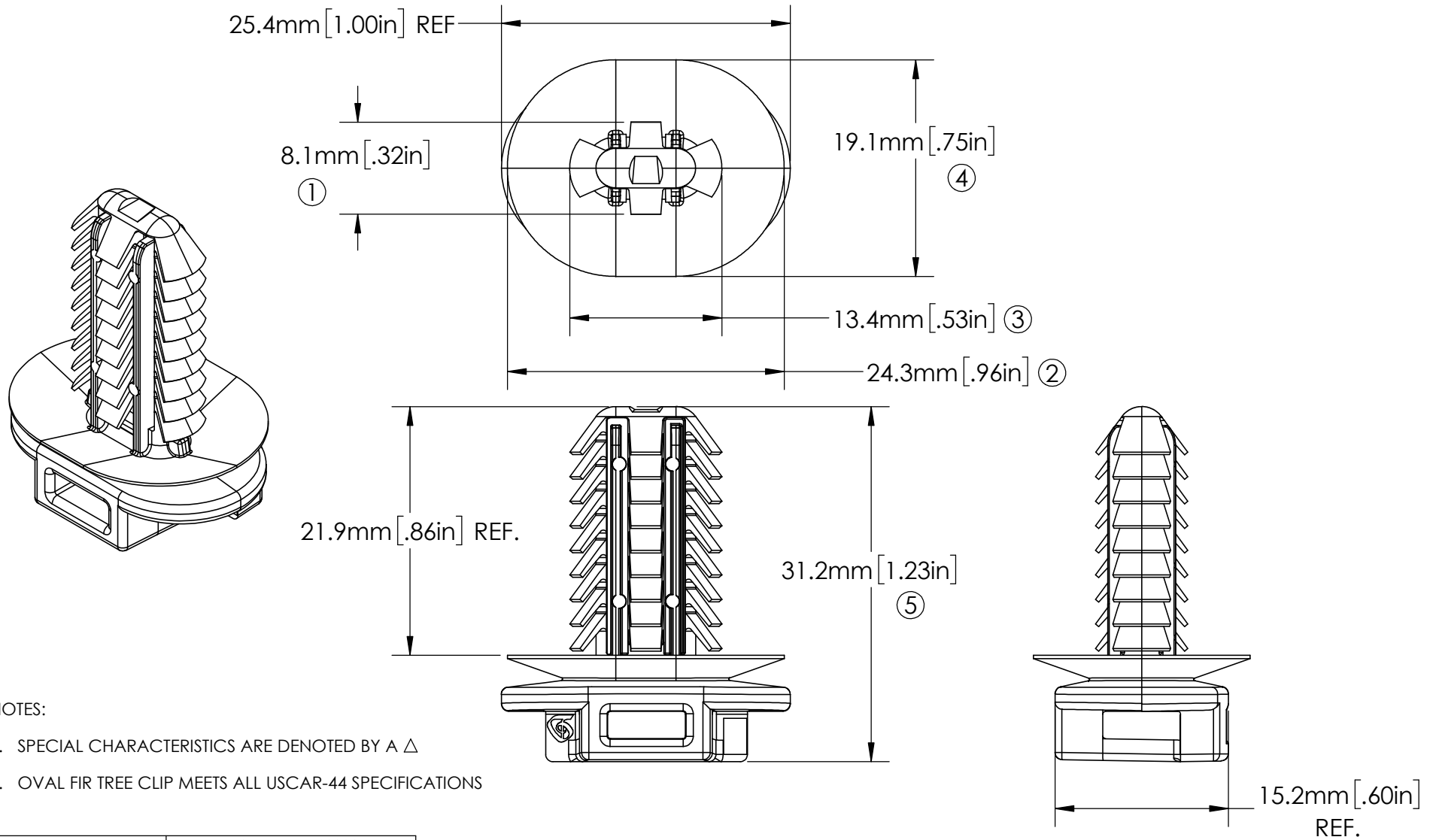

NOTES:

1. SPECIAL CHARACTERISTICS ARE DENOTED BY A  $\Delta$
2. OVAL FIR TREE CLIP MEETS ALL USCAR-44 SPECIFICATIONS

⑥ $\Delta$	FLAMMABILITY:	HB RATING PER FMVSS302
	MOUNTING:	6.2mm X 12.2mm ; 6.5mm X 12.5mm ; 6.5mm X 13.0mm ; 7.0mm X 12.0mm THICKNESS OF 0.6mm TO 16.0mm
	INSERTION:	10lbf / 44.5N MAX
	EXTRACTION:	NOM. FORCES: >40lbf / 178N MIN
	OPERATING TEMP RANGE:	-40°F (-40°C) TO 257°F (125°C) CONTINUOUS AND 257°F (135°C) AT MAXIMUM EXPOSURE
	OVAL FIR TREE CLIP WGT:	2.5g
	PACKAGING:	1000 CLIPS/BAG, 5/BOX

APPROVALS:	ENG. APPR.	<i>D. Gilbertson</i>	04.17.22
	Q.A. APPR.	<i>R. Estano</i>	04.17.22

SPECIFIED TOLERANCES ARE:

.XX ± .03 INCHES	.X ± .7 mm
.XXX ± .010 INCHES	.XX ± .25 mm
ANGULAR: ± 2°	

MATERIAL	PA66, IMHS
COLOR	BLACK



FASTENER DIVISION  
 FITCHBURG, MA 01420 U.S.A.  
 TEL. 1-800-225-5913  
 FAX. 978-353-8157

DESCRIPTION	OVAL FIR TREE CLIP, 24mm, IMHS	
STOCK NO.	<b>20316-0</b>	REV. <b>A</b>

# AVERY DENNISON MARKETING SPECIFICATION

© 2021 AVERY DENNISON CORPORATION. ALL RIGHTS RESERVED

## HISTORY

REV	DATE	DESCRIPTION
A	05.17.21	RELEASED

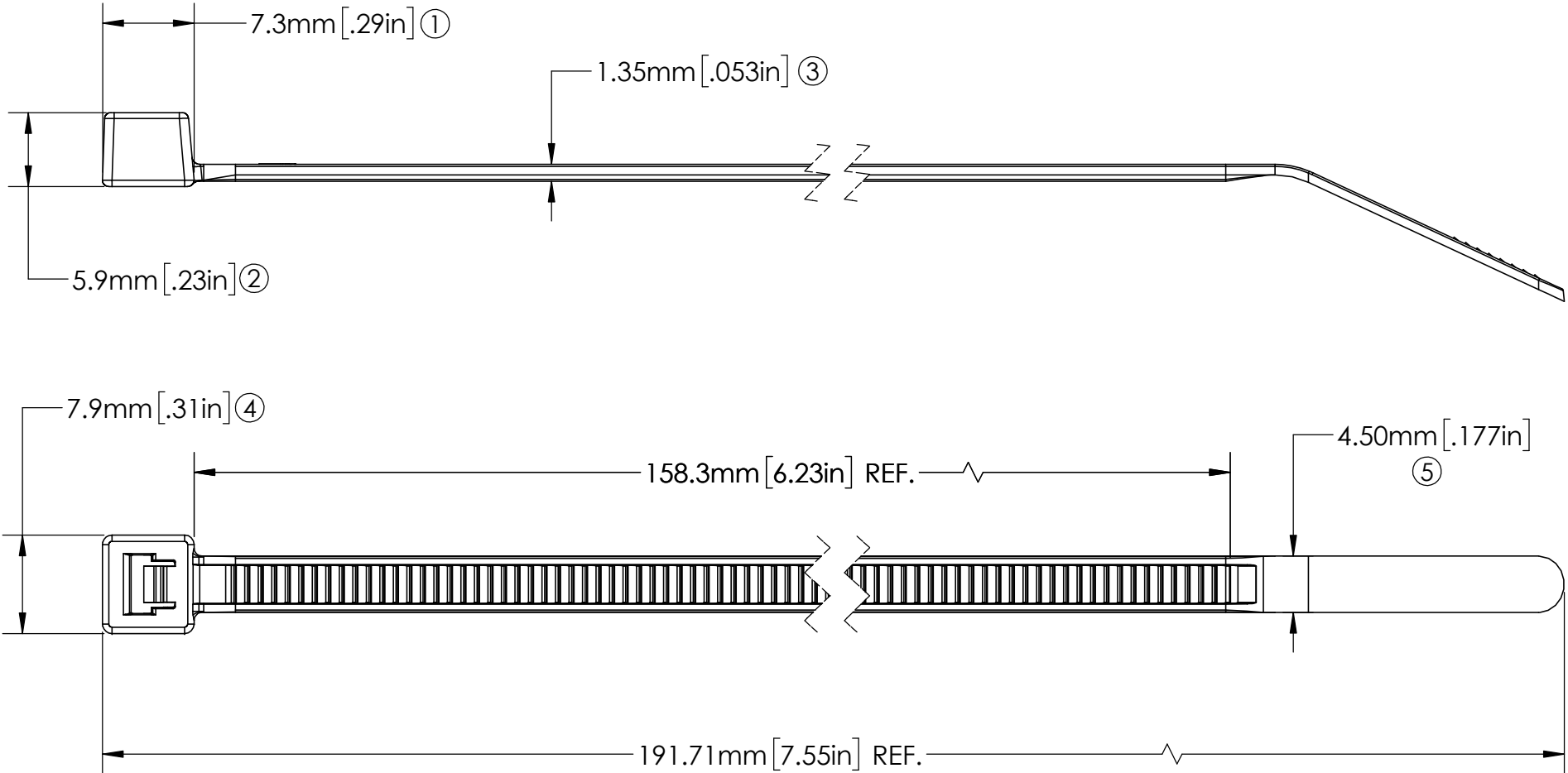

NOTES:

1. SPECIAL CHARACTERISTICS ARE DENOTED BY A  $\Delta$

⑥ $\Delta$	FLAMMABILITY:	HB RATED PER FMVSS302
⑦ $\Delta$	TENSILE STRENGTH:	50 lbf / 220N MIN.
	OPERATING TEMP RANGE:	-40°F (-40°C) TO 239°F (115°C) CONTINUOUS AND 257°F (125°C) AT MAXIMUM EXPOSURE
	WEIGHT:	1.2g
	BUNDLE DIAMETER:	$\phi$ 1.6mm TO $\phi$ 44.5mm
	TOOL:	12001 - HAND TOOL 12500 - PNEUMATIC TOOL
	TOOL TENSION SETTING:	6 - 8
	PACKAGING:	1000/BAG, 5000/CASE

APPROVALS:

ENG. APPR.	<i>D. Gilbertson</i>	05.17.21
Q.A. APPR.	<i>R. Estano</i>	05.17.21



FASTENER DIVISION  
FITCHBURG, MA 01420 U.S.A.  
TEL. 1-800-225-5913  
FAX. 978-353-8157

SPECIFIED TOLERANCES ARE:

.XX $\pm$ .03 INCHES	.X $\pm$ .7 mm
.XXX $\pm$ .010 INCHES	.XX $\pm$ .25 mm
ANGULAR: $\pm$ 2°	

MATERIAL	NYLON66, IMHS
COLOR	BLACK

DESCRIPTION	7.5" CABLE TIE, STD, IMHS	
STOCK NO.	<b>12101-0</b>	REV. <b>A</b>